

Lightning Protection Assembly Standards for Level 3 Distribution Boxes

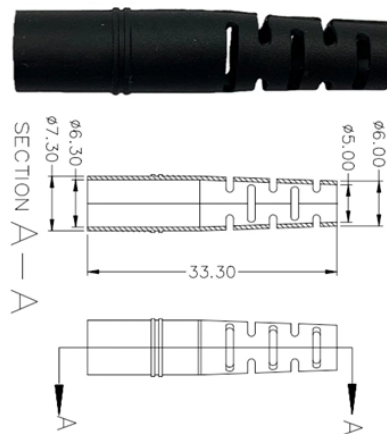

Overview

BS EN IEC 62305-3 defines three accepted methods: air terminals (Franklin rods), meshed conductors, and catenary wires. The Lightning Protection Institute is a nationwide not-for-profit organization founded in 1955 to promote lightning protection education, awareness, and safety. The lightning protection industry began in the United States when Benjamin Franklin postulated that lightning was electricity, and a metal rod was approved by the American National Standards Institute. This process brings together volunteers representing varied viewpoints and interests to achieve consensus on fire and other safety issues. Both nVent Engineered Electrical & Fastening Solutions is a leading global manufacturer and marketer of superior engineered products for niche electrical, mechanical and concrete applications. While the NFPA administers the process and establishes rules to promote fairness in the. BS EN IEC 62305-3 addresses this threat through systematic design of external lightning protection systems (LPS) that safely intercepts, conducts, and disperses lightning energy into the earth.

Lightning Protection Assembly Standards for Level 3 Distribution B



The National Fire Protection Assoc. (NFPA) publishes document # 780 titled Standard for the Installation of Lightning Protection Systems, an ANSI Standard, considered the national design guide for ...



The specification of a lightning protection system should require that the design complies with the IEC 62305 series of design standards and that materials comply with the EN 50164 series of component ...



IEC 62305-3 specifies the minimum number of down conductors based on the structure's perimeter and the LPL (Lightning Protection Limit), the permitted materials (copper, aluminum, galvanized steel), ...



In this article, we will be referring separately to design and component standards for Lightning Protection and Earthing. The Light Protection Design engineer or installer uses the design ...



BS EN IEC 62305-3 guide covering lightning protection system design, inspection methods, and maintenance requirements for structural compliance.



Description: UFC 3-575-01 provides policy and guidance for design criteria and standards regarding static electricity protection, lightning protection systems and related grounding for facilities and other ...



The need for certified lightning protection is increasing, and this guide looks at the requirements that support a safer, code-compliant installation.



It covers the scope, applicable standards and regulations, design process, construction requirements, testing procedures, quality certification, and delivery ...



In this guide, we will explore the core aspects of the IEC standard for lightning protection, its importance, how it is applied in real-world situations, and ...



N 4.2.5* Lightning protection systems shall be designed to mini-mize the effects caused by runoff from both copper and alumi-num lightning protection materials to prevent the deterioration of incompatible ...



Complete IEC 62305 lightning protection guide covering risk assessment (Part 2), LPS classes I-IV, rolling sphere method, down conductors, air termination, and SPD selection. Free reference.



The provisions of this standard reflect a consensus of what is necessary to provide an acceptable degree of protection from the hazards addressed in this standard at the time the standard was issued.



BS EN IEC 62305-3 guide covering lightning protection system design, inspection methods, and maintenance requirements for structural ...

Contact Us

For more information, pricing, or custom data center solutions, please contact us:

Website: <https://yoahorroenergia.es>

Email: hello@yoahorroenergia.es

Phone: +233 54 318 7269

Address: Plot 28, Spintex Road, Accra, Greater Accra, Ghana

This document is for informational purposes only. Specifications subject to change without notice.

